

MATHEMATICAL MODEL OF QUASISTATIONARY CONDITIONS OF MASS TRANSFER IN AN ELECTRODIALYSIS CELL

M. N. Khanmamedov

UDC 628.165.087.97+628.337

The author suggests a quasistationary mathematical model of the mass-transfer conditions in an electro dialysis cell in which the main operating parameters of the electro dialysis apparatus are expressed as a function of the dimensionless diluate concentration.

In [1], a quasistationary mathematical model of the mass-transfer conditions in an electro dialysis cell is described. The model allows calculation of the parameters that are of importance for optimum operation of the electro dialysis apparatus. Its main parameters U_c , i , L are presented as functions of the dimensionless concentrations $X = C_b/C_d$ and $Y = C_d/C_{in}$.

We offer the possibility of representing the main operating parameters of an electro dialysis apparatus as a function of just the dimensionless concentration Y . In doing so, we employ the assumptions and notation adopted in [1].

The calculated average current density along the path in an electro dialysis cell is determined by the expression [1] (see Fig. 1)

$$i_{av} = \frac{1}{L} \int_0^L i(l) dl. \quad (1)$$

The relation of the membrane area F_m required for attaining the desired degree of demineralization ΔC , the output capacity of the apparatus V_o , and the average current density i_{av} is determined according to the Faraday law as

$$F_m = \frac{FV_o\Delta C}{\eta i_{av}}. \quad (2)$$

The total area F_m and the output capacity V_o can be expressed as

$$F_m = mLn_m, \quad (3)$$

$$V_o = vmd_d n. \quad (4)$$

After transformation, expression (2) acquires the form

$$L = \frac{Fvd_d\Delta C}{\eta i_{av}}. \quad (5)$$

For further analysis, it is necessary to know the quantitative relationship between $C_d(l)$ and $C_b(l)$ since its representation in [1] is inadequate.

"Ekologiya" Science and Production Center, Ashgabat. Translated from *Inzhenerno-Fizicheskii Zhurnal*, Vol. 73, No. 4, pp. 839-843, July–August, 2000. Original article submitted November 3, 1998; revision submitted February 1, 1999.

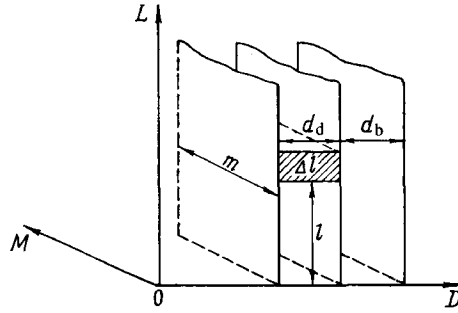

Fig. 1. Calculation scheme of the demineralization process in the electro-dialysis cell.

Let M_o , M_d , and M_b be the mass flow rates of the salts (kg/sec) in the overall flow and the flows in the diluate and brine chambers; let V_o , V_d , and V_b be the volume flow rates (m^3/sec) in the overall flow and the flows in the diluate and brine chambers. Then we can write

$$M_o = M_d + M_b, \quad (6)$$

$$V_o = V_d + V_b, \quad (7)$$

$$V_o C_{in} = V_d C_d + V_b C_b. \quad (8)$$

On the other hand,

$$V_d = m d_d v, \quad (9)$$

$$V_b = m d_b v, \quad (10)$$

$$V_o = m (d_d + d_b) v. \quad (11)$$

Substituting (9)-(11) into (8), we arrive at

$$C_{in} m (d_d + d_b) v = m d_d v C_d + m d_b v C_b, \quad (12)$$

whence

$$C_d(l) = \frac{1}{d_d} [C_{in} (d_d + d_b) - C_b d_b] \quad (13)$$

or

$$C_d(l) = C_{in} [1 + \beta (1 - XY)]. \quad (14)$$

Equation (14) can be represented in the form

$$C_d(l) + \beta C_b(l) = C_{in} (1 + \beta). \quad (15)$$

If $\beta = 1$, then

$$C_d(l) + C_b(l) = 2C_{in}. \quad (16)$$

Differentiating equality (15) with respect to l , we find

$$\frac{dC_d(l)}{dl} = -\beta \frac{dC_b(l)}{dl}. \quad (17)$$

Now we present a differential analog of formula (2):

$$dF_m(l) = -\frac{FV_o}{\eta i(l)} dC_d(l). \quad (18)$$

With account for (3) and (4), equality (18) can be expressed as

$$d(mln_m) = -\frac{nFvmd_d}{\eta i(l)} dC_d(l), \quad (19)$$

or bearing in mind that $n_m = n$, we obtain

$$\frac{dC_d(l)}{dl} = \frac{\eta i(l)}{Fvd_d}. \quad (20)$$

Substitution of (20) into (17) yields

$$\frac{dC_b(l)}{dl} = \frac{\eta i(l)}{\beta Fvd_d}. \quad (21)$$

The voltage drop on a cell necessary for attaining the current density $i(l)$ at the point $l = 0$, i.e., at the cell inlet, can be expressed, according to [1], as

$$U_{c.inl} = 2 \frac{RT}{F} \ln X \frac{i_{in}}{C_{in}} \left[\left(\frac{\delta_m}{\chi} + \frac{d_d}{a} \right) \left(1 + \frac{1}{\beta X} \right) + KYC_{in} \right]. \quad (22)$$

Proceeding from expression (22), we can represent the relationship between the current density, voltage, and concentration for the point l in dimensionless form as

$$U_c(l) = 2 \frac{RT}{F} \ln \left(\frac{X+\beta}{Y} - \beta \right) + \frac{i(l)}{C_d(l)} \times \left\{ \left(\frac{\delta_m}{\chi} + \frac{d_d}{a} \right) \left[1 + 1 / \left(\frac{X+\beta}{Y} - \beta \right) \beta \right] + KYC_{in} \right\}. \quad (23)$$

Since $U_c(l) = U_{c.inl}$, according to (23) the current density at the point l can be expressed by the formula

$$i(l) = \frac{C_d(l) \left[U_{c.inl} - 2 \frac{RT}{F} \ln \left(\frac{X+\beta}{Y} - \beta \right) \right]}{\left(\frac{\delta_m}{\chi} + \frac{d_d}{a} \right) \left[1 + 1 / \left(\frac{X+\beta}{Y} - \beta \right) \beta \right] + KYC_{in}}. \quad (24)$$

Substitution of (24) into Eq. (20) yields

$$\frac{dC_d(l)}{dl} = \frac{-\eta C_d(l) \left[U_{c.inl} - 2 \frac{RT}{F} \ln \left(\frac{X+\beta}{Y} - \beta \right) \right]}{Fvd_d \left\{ \left(\frac{\delta_d}{\chi} + \frac{d_d}{a} \right) \left[1 + 1 / \left(\frac{X+\beta}{Y} - \beta \right) \beta \right] + KYC_{in} \right\}}. \quad (25)$$

Therefore after replacement of the variables we obtain an expression for the total path length of the flow L required for decreasing the dimensionless concentration of the diluate from Y_{in} to $Y_{c.out}$ in a single pass of it through an electro dialysis cell:

$$L = -\frac{Fvd_d}{\eta} \int_{Y_{in}}^{Y_{c.out}} \frac{\left(\frac{\delta_m}{\chi} + \frac{d_d}{a}\right) \left[1 + 1 / \left(\frac{X+\beta}{Y} - \beta\right) \beta\right] + KYC_{in}}{U_{c.inl} - 2 \frac{RT}{F} \ln \left(\frac{X+\beta}{Y} - \beta\right)} \frac{dY}{Y}. \quad (26)$$

Next with account for (15) we have

$$C_b(l) = \frac{C_{in}(1+\beta) - C_d(l)}{\beta}, \quad (27)$$

and then

$$X = \frac{C_b(l)}{C_d(l)} = \frac{1+\beta-Y}{\beta Y}. \quad (28)$$

Similarly, we find

$$f(Y) = \beta \left(\frac{X+\beta}{Y} - \beta\right) = \frac{1+\beta - (1-\beta^2)Y - \beta^2 Y^2}{Y^2}. \quad (29)$$

With account for (29), Eq. (26) acquires the form

$$L = -\frac{Fvd_d}{\eta} \int_{Y_{in}}^{Y_{c.inl}} \frac{\rho [1 + 1/f(Y)] + KYC_{in}}{U_{c.inl} - 2 \frac{RT}{F} \ln \frac{f(Y)}{\beta}} \frac{dY}{Y}, \quad (30)$$

where

$$\rho = \frac{\delta_m}{\chi} + \frac{d_d}{a}.$$

After replacement of the variables we can rewrite Eq. (24) as

$$i(l) = \frac{C_d(l) \left[U_{c.inl} - 2 \frac{RT}{F} \ln \frac{f(Y)}{\beta} \right]}{\rho [1 + 1/f(Y)] + KYC_{in}} \quad (31)$$

or with account for $C_d(l) = C_{in}Y$ we find

$$i(l) = \frac{C_{in}Y \left[U_{c.inl} - 2 \frac{RT}{F} \ln \frac{f(Y)}{\beta} \right]}{\rho [1 + 1/f(Y)] + KYC_{in}}. \quad (32)$$

In [1], the author gives the calculated average current density in the form

$$i_{av} = \frac{U_{c.inl} - 2 \frac{RT}{F} \ln X_N}{\frac{1}{C_{av}} \left[\frac{d_d + d_d/\chi_N + (\delta_{an}/\chi_{an} + \delta_{cat}/\chi_{cat}) \chi_{NaCl}}{\lambda [1 + 0.02 (T + N - 290)]} \right]} \quad (33)$$

Unfortunately, in [1] the procedure of derivation of formula (33) is not described, and therefore in practice its use is difficult. We will try to derive a similar formula within the framework of the presented theoretical approach.

Since the right-hand side of equality (32) is an explicit function of the variable Y , $i(l) = i(Y)$:

$$i_{av} = - \frac{1}{Y_{c.out} - Y_{in}} \int_{Y_{in}}^{Y_{c.out}} \frac{C_{in} Y \left[U_{c.inl} - 2 \frac{RT}{F} \ln \frac{f(Y)}{\beta} \right]}{\rho [1 + 1/f(Y)] + KYC_{in}} dY \quad (34)$$

Equations (30)-(34) describe the dependence of the structure parameters of the cells and the applied voltage on the demineralization effect and the average working current density.

Use of the suggested mathematical model for calculation of the parameters of an electro dialysis apparatus reduces the volume of computer-assisted calculations.

Thus, we have shown the possibility of representing the main operating parameters of the apparatus as a function of just the dimensionless dilute concentration, which substantially simplifies the traditional mathematical model and reduces the computer time for its numerical implementation.

NOTATION

U_c , voltage drop on the cell; i , current density; L , total path length of the flow; l , current value of the path length of the liquid flow in the chambers; Δl , its increment; i_{av} , average current density; F_m , area of the membranes; $\Delta C = C_{in} - C_d(l)$; C_{in} , electrolyte concentration at the cell inlet; $C_d = C_d(l)$, current value of the salt concentration in the diluate chamber; V_o , volume flow rate in the overall flow; F , Faraday constant; η , current yield; m , width of the liquid flow in the cells; n_m , number of membranes; v , linear velocity of the flow; n , number of cells; d_d , distance between the membranes of the diluate cell; d_b , distance between the membranes of the brine cell; $\beta = d_b/d_d$; V_d , volume flow rate in the flow in the diluate chamber; V_b , volume flow rate in the flow in the brine chamber; $X = C_b/C_d$, dimensionless concentration of the brine; $Y = C_d/C_{in}$, dimensionless concentration of the diluate; $F_m(l)$, current value of the membrane area; $i(l)$, current value of the current density; $U_{c.inl}$, voltage drop on a cell required for attaining the current density $i(l)$ at the point $l = 0$, i.e., at the cell inlet; Y_{in} and $Y_{c.out}$, dimensionless concentration of the diluate at the cell inlet and outlet, respectively; R , universal gas constant; i_{in} , current density at the beginning of the demineralization process; T , solution temperature; δ_m , δ_d , thickness of the membranes and the diluate, respectively; χ , electrical conductivity of the membranes; a , thickness of the swirler connectors; K , constant determining the electrical conductivity of the membranes; C_{av} , average concentration of the diluate along the length of the cell; N , number of demineralization stages; X_N , dimensionless brine concentration at the end of the path; λ , equivalent electrical conductivity of the solution; χ_{an} and χ_{cat} , electrical conductivity of the anionite and cationite membranes, respectively; δ_{an} and δ_{cat} , thickness of the anionite and cationite membranes, respectively. Subscripts: b, brine; d, diluate; in, initial; m, membrane; o, overall; c, cell, c.inl, at the cell inlet; c.out, at the cell outlet; av, mean.

REFERENCES

1. V. I. Smagin, *Treatment of Water by the Electrodialysis Method* [in Russian], Moscow (1986).